



Western States Forum

June 2008

ODOT Traveler Information Systems
Galen McGill PE



ATIS Vision

- Create Traveler Information Portal for Oregon
 - Focus on usability
- Technology platform for aggregating and sharing ATIS data
- Share Information through multiple outlets
- Partnerships with other organizations
 - Public & Private



ODOT ATIS History

- 1995 – OSP transfers 976-PASS to ODOT
- 1997 – Toll free phone line & Travel Advisor web site
- 1998 – Bend Cable TV system
- 2000 – TripCheck web site
- 2001 – Automated phone system

The screenshot shows the Oregon Department of Transportation TripCheck website. At the top, it features the ODOT logo and the text "Oregon Department of Transportation". Below this is the TripCheck logo with the tagline "Get answers. Get going." and a "Current Road Conditions" section with phone numbers: "1-800-977-ODOT (6368)" and "Outside of Oregon: 1-503-588-2941". A "Top Web Site for Traffic" award badge is displayed, along with a text box stating: "TripCheck has been recognized by the US Department of Transportation as one of the best travel information Web sites in the nation. Click here to learn more." The main content area lists features: "Roadway Incident Maps" and "Over 100 Road Cams". A navigation menu on the right includes: "Road Conditions", "Road Cams", "Winter Travel Info", "Other Ways To Go", "General Information", and "Contact Us". At the bottom, there is a "QuickCheck" button and a "OTIA" logo with the text "Click here to learn more about Oregon Transportation Investment Act Projects".



ODOT ATIS History

- Dec. 2003 – 511 Service
- May 2005 – TripCheck 2.0
- April 2006 – TTIP System
- May 2006 Cable TV upgrade
- Feb. 2007 – Transportation Options System (Transit)
- July 2007 – TripCheck Mobile system
- 2008 – 511 System replacement



ODOT Traveler Information Services

- TripCheck
 - web site
 - Mobile web site
- 511 System
- Cable TV
- Rest area system
 - Audio using 511 system
- TripCheck Traveler Information Portal (TTIP)
 - XML data for other agencies and private sector

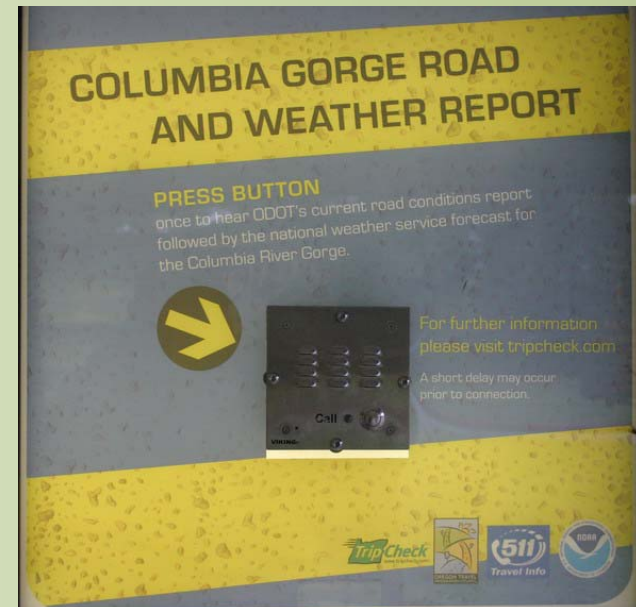



Benefits of ATIS

- Demand Management
 - Shift route
 - Shift time of travel
 - Shift mode
 - 2003 survey, 38% definitely change travel plans based on ATIS data
- Improve safety
- Reduce calls to ODOT offices
- Customer Service



ATIS Usage

Average Monthly Visits to TripCheck.com

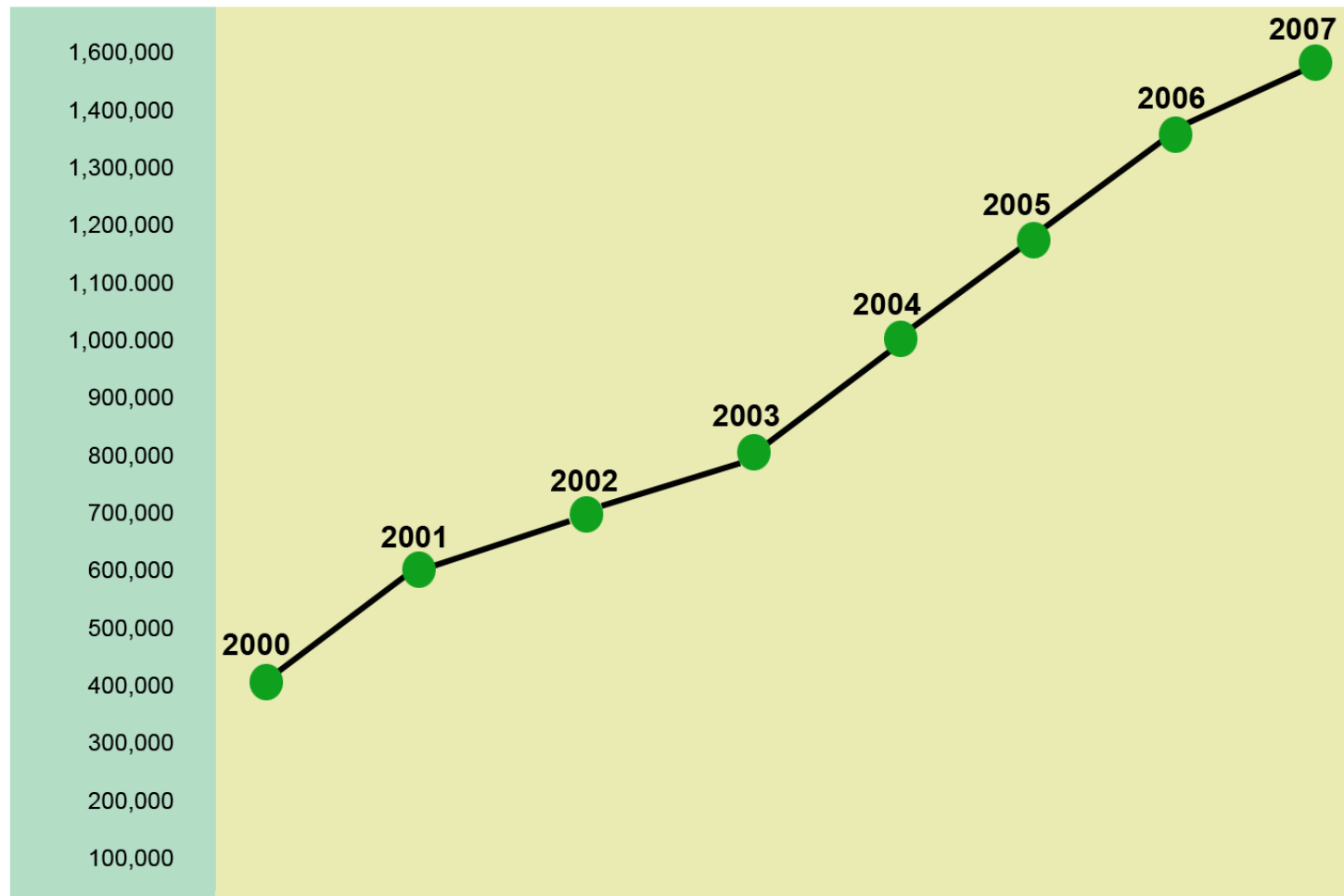



OREGON DEPARTMENT OF TRANSPORTATION

TripCheck

Road | Weather | Travel Center | Transportation Options | About TripCheck | View Text Report

Road Conditions | Weather Outlook | Cameras | Custom Cams | Trucking Center

Select Region Map:

- [Northwest](#)
- [North](#)
- [Northeast](#)
- [West](#)
- [Central](#)
- [East](#)
- [Southwest](#)
- [South](#)
- [Southeast](#)

Or City Map:

- [Bend](#)
- [Eugene](#)
- [La Grande](#)
- [Medford](#)
- [Portland](#)
- [Portland Metro](#)
- [Speed Map](#)
- [Salem](#)

Winter Travel

- [Chain Law](#)
- [Traction Tires](#)
- [Minimum Chain Requirements](#)

Welcome to TripCheck

Click on the map below or the links to the left to view road conditions within Oregon and its surrounding states.

[View Travel Services](#)

[Printer-Friendly Contact Us](#)





TripCheck Features

- Alerts
- Incidents
- Portland SpeedMap
- Road Conditions
- Chain Requirements
- Truck Restrictions
- Cameras
- Weather
- Construction
- Maintenance
- Transit
- Travel Services
- Scenic Byways
- Rest Areas & Sno-parks



Images



Incidents

ORE242 MP 83.71 - 61.91 ORE242, 7 miles West of Sisters	Seasonal Closure Weather Impact
Lanes Affected: (Westbound) Median , All Lanes , Shoulder (Eastbound) Median , All Lanes , Shoulder Comments: Old McKenzie pass is closed due to high snows. See TripCheck.com for details. Closed to all vehicles including bicycles, probable opening from East end to summit expected mid to late July.	
Click here for additional information	
Public Contact: ODOT/CTOC Bend	Phone: (541) 383-0121
Incident #: 51339	Last Updated: 05/07/2008 07:42 am

SpeedMap

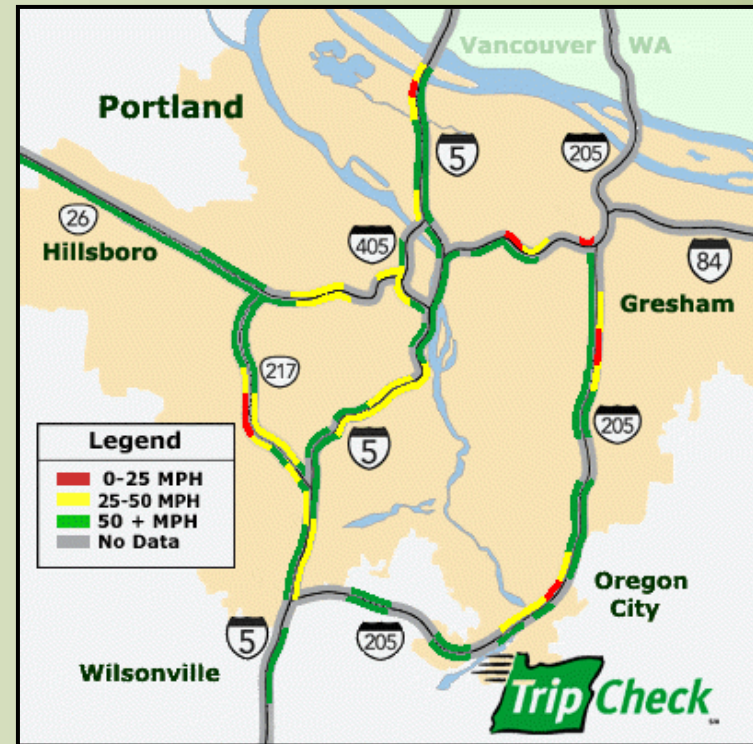

Alerts

Alerts!	
Area	Details
ORE569, Eugene MP 10 - 11	Closure Off ramp from Beltline to Delta is closed due to crash. Please use alternate route and drive with caution. Updated: 05/08/2008 06:16 am



Transit

Cherriots

Cherriots provides fixed route bus service and paratransit service to the general public in the Salem Keizer area.

Trip Planning Assistance:
[System Map](#)
[Routes & Schedules](#)
[Park & Rides](#)

Customer Service:
 Phone: 503-588-2877
 Voice Response: 503-588-2877
 Email: info@cherriots.org
[Website](http://www.cherriots.org)

Hours:
 Phone hours: 6:15am-9:30 pm, M-F; 7:45am-9:30pm, Sa
 Automated voice response hours: 24/7

Offices:
 220 High Street, NE
 Salem, OR 97301

Hours:
 6:15am-9:30 pm, M-F; 7:45am-9:30pm, Sa

Related Links

[Amtrak](#)
[Greyhound](#)
[SMART](#)
[CARTS](#)

Cities Served:
Oregon—Keizer, Salem

Counties Served:
Oregon—Marion County, Polk County

Days of Operation:
M Tu W Th F Sa

Fares:
\$1 Basic Adult Fare. Other fares vary - please call (503) 588-2877 or go to our website. Discounts: senior, child. [Details](#)

Accommodations:
Meets ADA requirements

Wheelchair
Walker

Weather

Cascades in Lane County

Including McKenzie Pass, McKenzie Bridge, Willamette Pass, Oakridge

330 AM PDT THU MAY 8 2008

Today

Today, mostly cloudy with occasional drizzle or brief light rain in the morning north of santiam pass. Becoming partly sunny this afternoon south of santiam pass. Snow level 4000 feet. Pass winds northwest 5 to 15 mph.

Tonight

Tonight, mostly cloudy. Free air freezing level 4500 feet. Pass winds northwest 5 to 15 mph.

Friday

Friday, morning clouds, becoming partly to mostly sunny by early afternoon. Free air freezing level rising to 7500 feet. Pass winds northwest 5 to 10 mph.

Friday Night

Friday night, mostly clear. Free air freezing level 9000 feet. Pass winds northwest 10 mph becoming light after midnight.

Saturday

Saturday, increasing clouds. Free air freezing level 9000 feet. Pass winds southwest 5 to 10 mph.

Saturday Night

Saturday night, cloudy. Chance of rain. Snow level 8000 feet lowering to 6000 feet after midnight.

Sunday

Sunday, mostly cloudy. Chance of showers. Snow level 5000 feet.

Motor Carrier

Travel Services

Map Legend

- Offices
- Ports of Entry

Trucking Links

- [ODOT Motor Carrier Transportation Division](#)
- [Oregon Truck Safety](#)
- [Motor Carrier Registration Service](#)
- [Over-Dimension Permit Service](#)

Trucking Center

Click on the map below to obtain information about Oregon registration offices and ports of entry.

[View Travel Services](#)

Beachcombers Haven



Motel

15 vacation rentals, mix of condo-type units and houses. Ocean/beach views, some beachfront; all within 50-200 ft. of easy beach access. Excellent for family reunions, group retreats, sewing/craft groups. Fully furnished and equipped.

Hours of Operation

Summer office hours: 9:00 am - 7:00 pm Monday - Friday, 9:00 am - 6:00 pm Saturday - Sunday.
Winter office hours: 9:00 am - 5:00 pm Monday - Friday, 9:00 am - 4:00 pm Saturday - Sunday.

Amenities

- Cable TV
- Golf
- Kitchen

Fees

On-season \$137.50 - \$275.00 per night. Off-season 3 for 2, low weekly and monthly rates.

Payment Options

- VISA
- MasterCard
- Check

Address

7045 NW Glen
Gleneden Beach, OR, 97388

[Printer-Friendly](#)
[Contact Us](#)

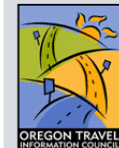

[Get Your Business Listed on TripCheck!](#)





Infrastructure Summary

- 50 Servers
- 15 Systems
- 50 Applications
- 100+ Components



System Architecture Overview

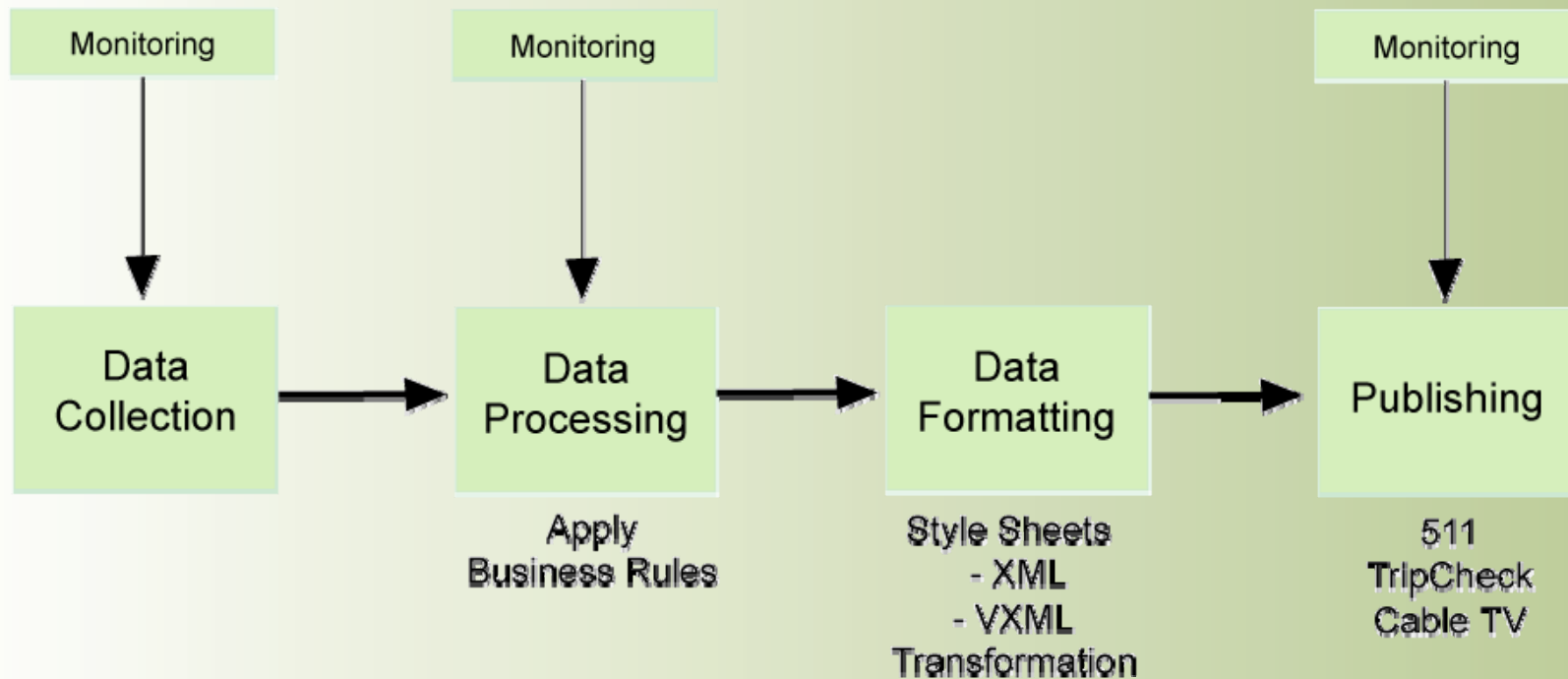



ODOT ATIS

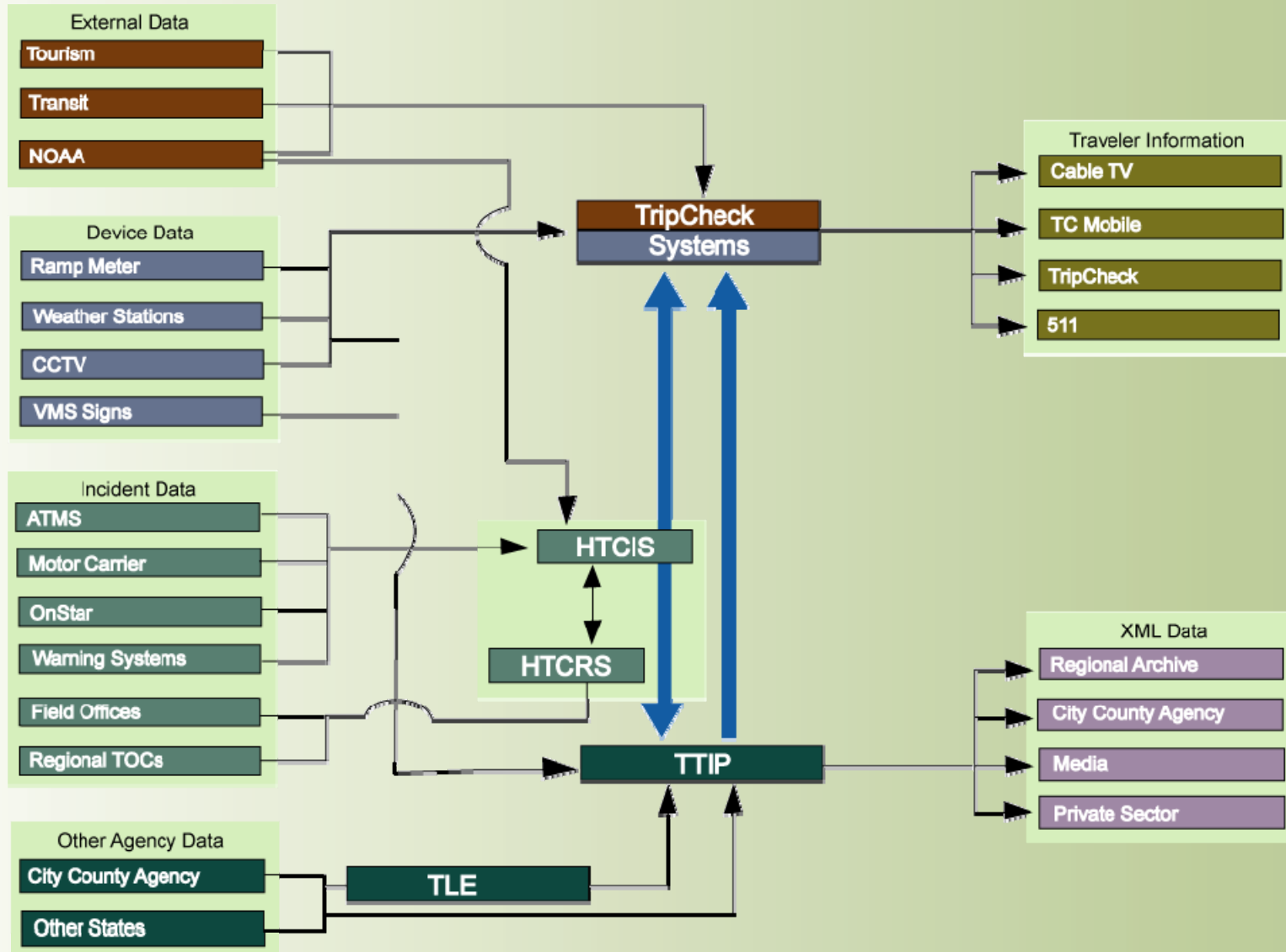



External Data

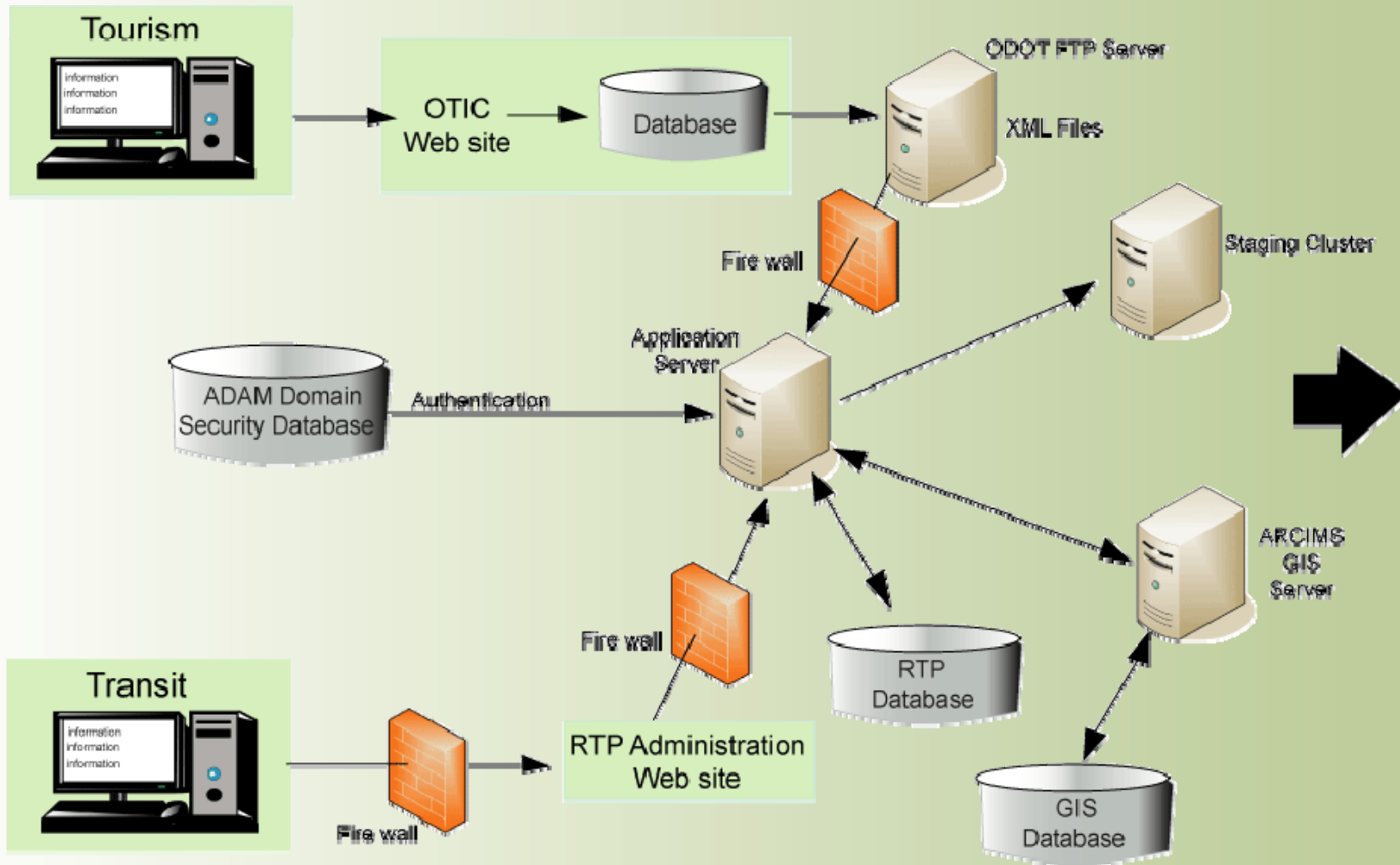



About Authentication

- Trusted subsystem concept
- Security
 - Login ID & Password
 - System Administrator sets agency permission level
 - Agency Administrator sets user permission level
- Isolation of web site from database through business tier



Travel Services Admin.

Oregon Travel Information Council

Administration Website LOGOUT

[Fuel](#) [Food](#) [Lodge/Camp](#) [Attractions](#) [Tourism Assoc.](#)

[Edit Users](#)
[View/Edit Images](#)
[View OTIC Zones](#)

Lodging/Camping/RV: Edit

All fields preceded by an * (asterisk) are required and must be filled in before continuing to the next part of the form.

Part 2: Business Profile (information released to public)

Facility Description	
*Hours of Operation: (one paragraph max.; 250 characters max.)	<input type="text" value="24-hour, year round"/>
Fees: (one paragraph max.; 250 characters max.)	<input type="text"/>
Payment Options: <input type="checkbox"/> Cash <input type="checkbox"/> VISA <input type="checkbox"/> MasterCard	*ADA Accessible? <input type="radio"/> Yes <input checked="" type="radio"/> No
	Amenities: <input type="checkbox"/> Air Conditioning <input type="checkbox"/> Business Service Ctr <input type="checkbox"/> Cable TV <input type="checkbox"/> Exercise Equipment <input type="checkbox"/> Free Breakfast <input type="checkbox"/> Golf <input type="checkbox"/> High-Speed Internet <input type="checkbox"/> Kitchen <input type="checkbox"/> Kitchenettes <input type="checkbox"/> Movies



Transportation Options Admin.

Transportation Options
Welcome tdb215 LOGOUT

Agency Service Manage Announcements Manage Users Reports Admin

[Service Provider User Manual](#) [Questions?](#)

You have logged in with DOT system administrator privileges. These include read, edit, and approve capabilities for all Agencies, Services, and Users in the system and access to all data maintenance application functionality.

Transportation Options
Welcome tdb215 LOGOUT

Agency **Service** Manage Announcements Manage Users Reports Admin

[Home](#) > [Service Listing](#) [Questions?](#)

The following list shows transportation services in the RTO system.

You can sort this list by:

Find Service By: Service Name:

Or click on alphabet index: [A](#) [B](#) [C](#) [D](#) [E](#) [F](#) [G](#) [H](#) [I](#) [J](#) [K](#) [L](#) [M](#) [N](#) [O](#) [P](#) [Q](#) [R](#) [S](#) [T](#) [U](#) [V](#) [W](#) [X](#) [Y](#) [Z](#) [All](#)

Service Records							
Agency Name	Service Name	Service Profile	Target Audience	Mode	Active?	Status	
A-Cab Taxi	A-Cab Taxi	Local Service	General Public	Taxi	Yes	Published	Edit
Airport City Taxi Limousine	Airport City Taxi Limousine	Local Service	General Public	Taxi	Yes	Published	Edit
Albany Transit System	Albany Call-A-Ride	Local Service	Restricted	Dial-A-Ride	Yes	Published	Edit
Albany Transit System	Albany Transit System	Local Service	General Public	Bus	Yes	Published	Edit
Albany Transit	Linn-Benton Loop	Local Service	General	Bus	Yes	Published	Edit

Transportation Options
Welcome tdb215 LOGOUT

Agency **Service** Manage Announcements Manage Users Reports Admin

[Home](#) > [Service Listing](#) > [Service Record](#) > [Edit Service Demographics](#) [Questions?](#)

Edit the form content below, then click "Submit Edits."
Note: All edits must be approved prior to display on the public website.
*Indicates required fields

Service Description

Service Description*:
One paragraph; text only; max. 300 characters

Logo: Upload new image [here](#) or copy & paste from [this list](#) (.jpg or .gif only; cannot exceed 225 pixel width)

Days of Operation*: Su M Tu W Th F Sa

Fare Summary*:
One paragraph; text only; max. 125 characters

Fare Discounts: Seniors Children

Additional Fare Information: Enter a URL OR Link a pdf document

 Is this a secure (https://) website?
PDF document: Upload new pdf document [here](#) or [select](#) from existing pdf documents in the RTP system.

Reservations*: Reservations Required Reservations Recommended Reservations Not Required





Weather Data

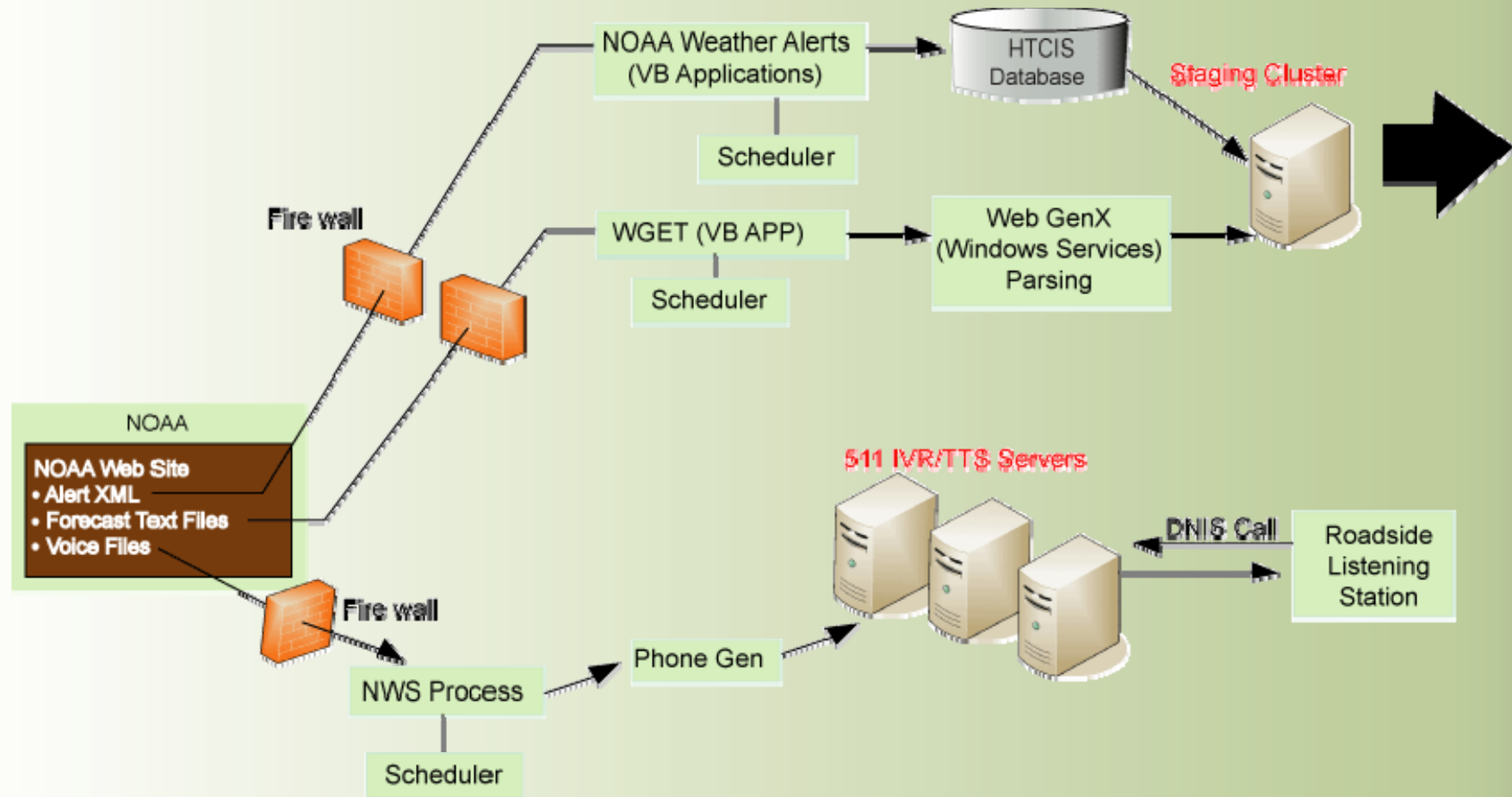



About the Scheduler

- ODOT Custom application
 - .Net/C#
- One application on multiple servers
 - Initiates file update processes
- Server Sitter application to monitor Scheduler and restart as necessary



About the Scheduler

- Traveler Information update cycles
 - RWIS – 5 minutes
 - HTCIS – 3 minutes
 - TTIP – 3 minutes
 - OTIC/Travel Services – Once per day
 - NOAA Forecast – Once per day
 - NOAA Alert – 1 minute
 - Transit – Once per day



RWIS Data

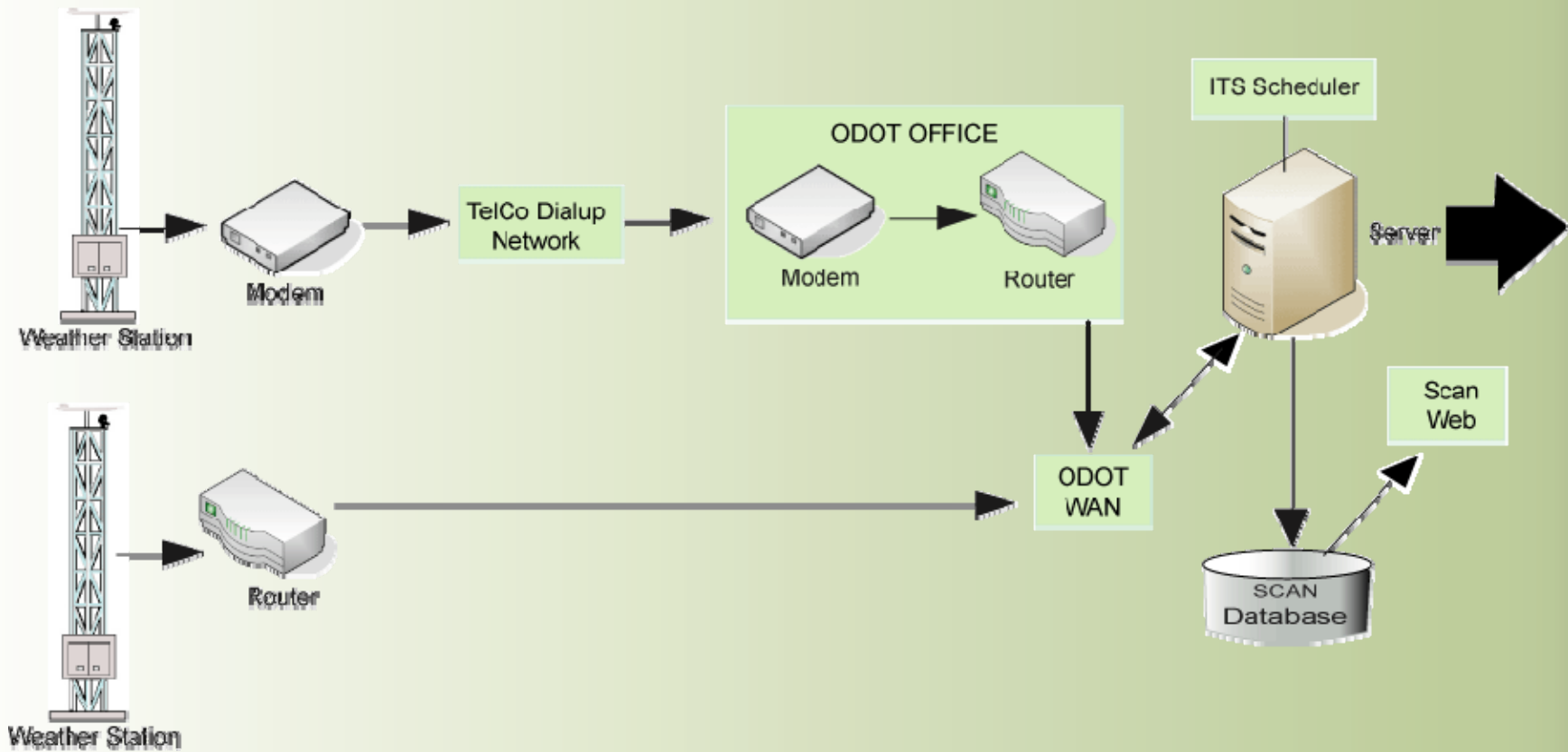



CCTV Images

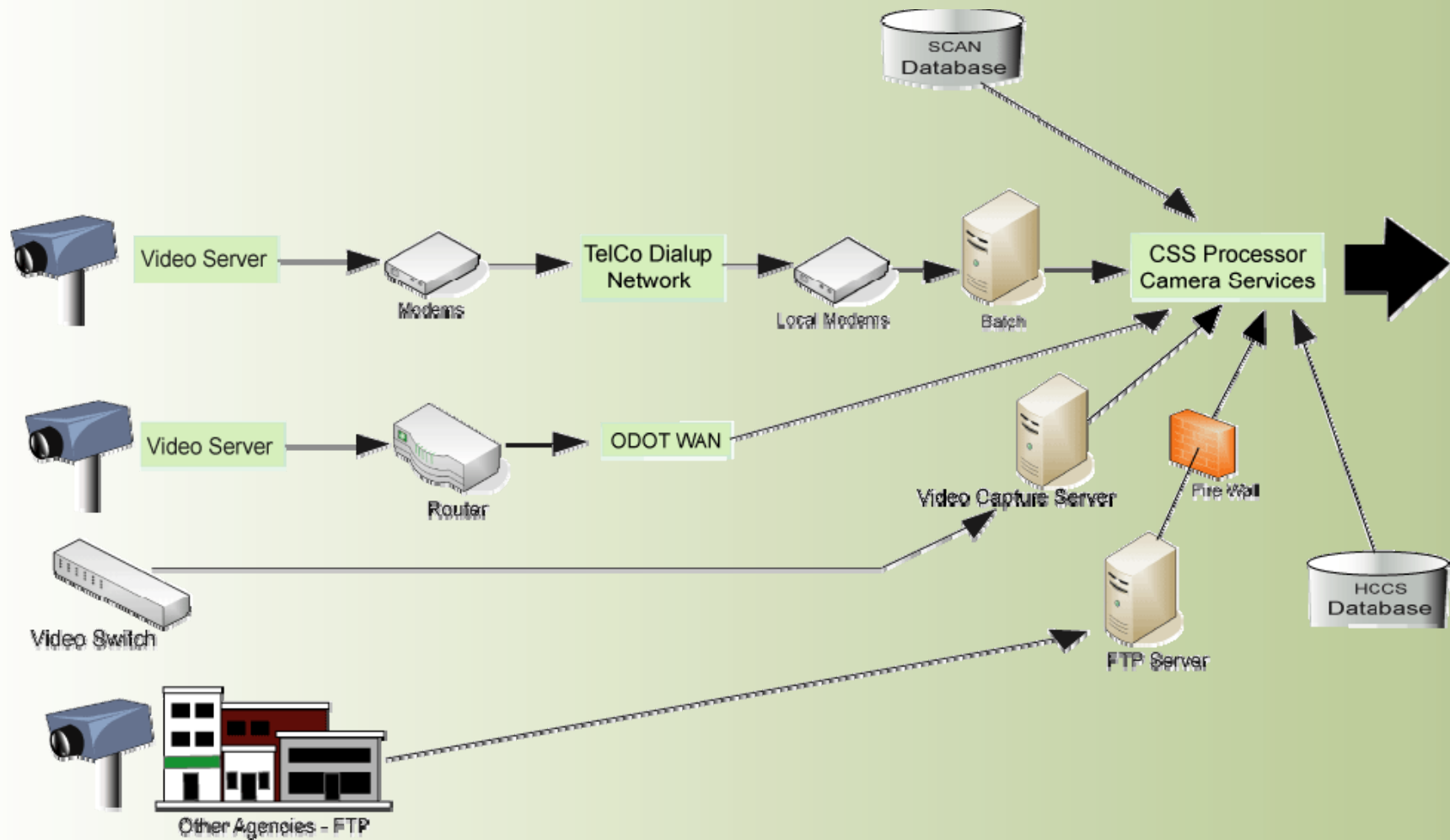



About Camera Services

- VB and .Net/C# Applications
 - Processes Images
 - Creates Templates
 - Creates individual “Published Images”
 - Supports Editing of Images
 - Distributes Images



Camera Services

CSSMaint! -- Camera Service Support Maintenance

Tree Record Application CsmMonitor

- Server: \\s-salemtoc-102
- Server: \\xd0441Q
- Server: \\xd0441Q
- Server: \\xd4210e
- Server: \\xd4210g
- Server: Arlington
- Camera: Arlington
- Server: Arndt Rd
- Server: Astoria
- Camera: AstoriaUS101
 - Cable Standard AstoriaUS101
 - MobileAstoriaUS101_L
 - MobileAstoriaUS101_S
 - Standard AstoriaUS101 2.0
- Camera: AstoriaUS101MeglerBrNB
- Camera: AstoriaUS101MeglerBrSB
- Camera: AstoriaYoungsBayBr
- Server: Bend/Santiam Pass
- Server: Bly Mtn
- Server: Brightwood
- Server: CalTrans
- Server: Cape Cove
- Server: Cascade Locks
- Server: Chemult
- Server: Detroit
- Server: Emigrant
- Server: Government Camp
- Server: I-5Exit 6
- Server: Juniper Butte
- Server: Klamath Falls
- Server: LaddCreek
- Server: LaGrande
- Server: Lake Creek

Manage Image Cameras

CAMERA

Camera Port No.: 1 *Camera Active Status: Prod

*Camera Name: AstoriaUS101 Region No.: 2

*Camera's File Nm: fullsize4.jpg Region Camera No.:

Image Directory on Image Server: /

*Raw Format: 352 X 240,JPG,24 bit Camera ID: 175

LOCATION

Hwy No: 009 *Pointed Direction: N

*Hwy Route Name: US101 *Latitude: 46:00:00 (dd:mm:ss)

Mile Point: 3.70 *Longitude: -124:00:00 (dd:mm:ss)

Elevation: 30 *Time Zone: Pacific Time

*Public Description: US101 at Astoria - Columbia River

IMAGE PROCESSING

First Image After Sunrise: 15 Min Last Retrieval: 05/16/2008 11:47 AM

*Last Image Sunset: -20 Min File Timestamp: 05/16/2008 11:47 AM
- (before), + (after)

*Unavailable Lapse Time: 120 Min [Preview Published Images for this camera...](#)

Last Update: 06/21/2005 09:03 AM



CSSMaint! -- Camera Service Support Maintenance

Tree Record Application CmsMonitor

Server: \\s-salemtoc-102
Server: \\wd0441Q
Server: \\wd0441Q
Server: \\wd4210e
Server: \\wd4210g
Server: Arlington
Camera: Arlington
Server: Arndt Rd
Server: Astoria
Camera: Astoria
Cable Star
MobileAsto
MobileAsto
Standard A
Camera: Astoria
Camera: Astoria
Camera: Astoria
Server: Bend/Santi
Server: Bly Mtn
Server: Brightwood
Server: CalTrans
Server: Cape Cove
Server: Cascade Lo
Server: Chemult
Server: Detroit
Server: Emigrant
Server: Governmen
Server: I-5Exit 6
Server: Juniper But
Server: Klamath Fa
Server: LaddCreek
Server: LaGrande
Server: Lake Creek

Manage Image Cameras

CAMERA

Camera Port No.: 1 *Camera Active Status: Prod

*Camera Name: AstoriaUS101 Region No.: 2

*Camera's File Nm: fullsize4.jpg Region Camera No.:

CsslImagePreview

Environment Help

Raw Image Path: \\s-salemtoc-101\ITS\CameraServices\RawImages\
Camera Name: AstoriaUS101 Refresh

AstoriaUS101_pid261.jpg
 AstoriaUS101_pid496.jpg
 AstoriaUS101_pid1038.jpg
 AstoriaUS101_pid1244.jpg

US101 at Astoria - Columbia River
Updated: May 16 2008 11:52 AM Looking North



ODOT
Elevation 30 TripCheck.com Milepost 3.70
328w X 295h
FTP server: Astoria, template: TripCheck Standard 2.0





Incident Data

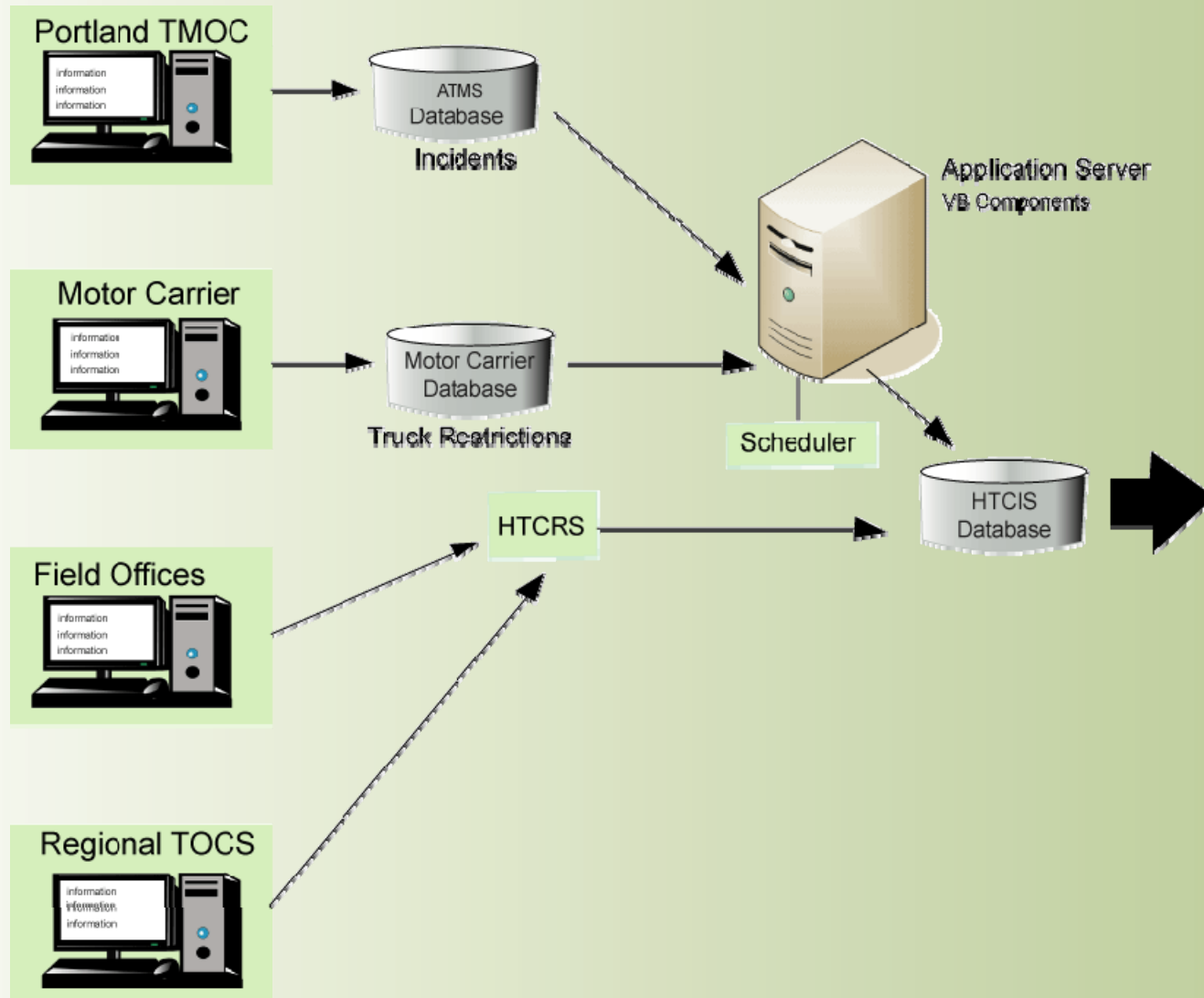



About HTCRS

- Client/Server VB application
 - Highway Travel Condition Reporting System (HTCRS)
 - Client Software for distributed entry of
 - Incidents
 - Alerts
 - Construction
 - Road & Weather Reports
 - Highway Travel Condition Information System (HTCIS)
 - SQL database



HTCRS

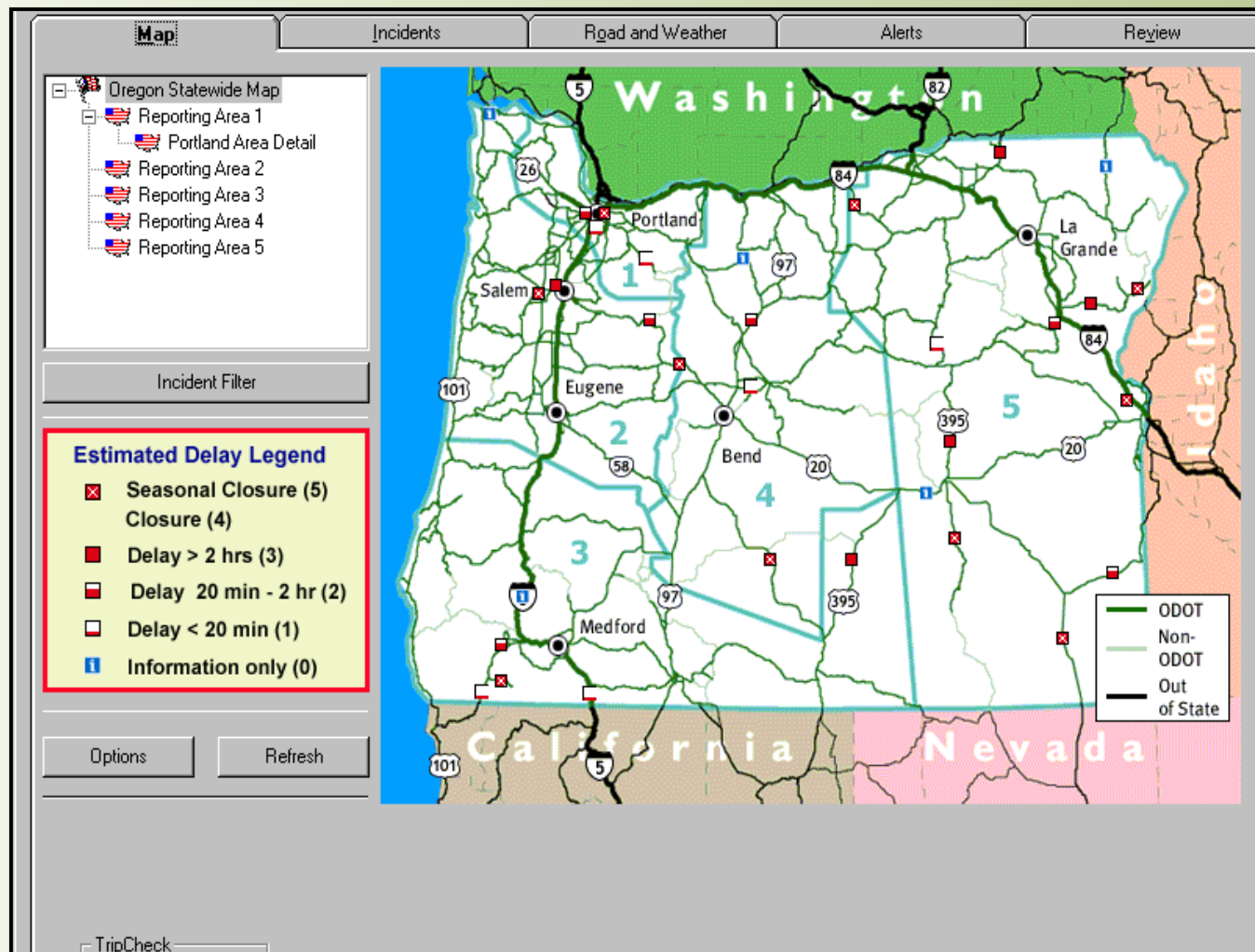



HTCRS

View/Edit Incident #36726; not related to any Alert - HTCRS 2.5.5

Location:
Route:
*Highway:
*Begin MP: auto check for 'Construction' incidents
End MP:
Marker:

Affected Lanes:
Southbound: M A B C D E S All
Northbound: M A B C D E S All

Off-Highway Options:

Incident Type and Severity:
Key In:
Or Select:
*Category:
*Severity:

Dates/Times:
*Start Date/Time:
*Estimated Clear Date/Time:
Cleared Date/Time:

Public Information | **Internal Information** | **Incident Information** | **History**

Common From:
Name To:
Headline:
Chars allowed: 150
Chars used: 103
Chars Avail: 47
Public Comment:
*Contact Name: Contact Phone:
Info URL:

Reviewed: by hwyr11z(Mike Mason) on 04-11-2008 15:04
(note: * = required field)



HTCRS

File Incidents Road/Weather Alerts Review Help

Map Incidents Road and Weather Alerts

View/Edit Road & Weather station #20; not related to any Alert - HTCRS 2...

Reporting Station: 20 SALEM (20, Hwy 1) - hwy09k Glen Hammer 05/15/2008 07:35
SALEM (20, Hwy 1) - hwy09k Glen Hammer 05/15/2008 07:35

Weather Condition: 91 - Severe Weather Alert - Freezing
Severe Weather Alert - Freezing Rain

Temperature: Current: 23 High: 25 Low: 13

Precipitation: Liquid: New Snow: 1 Roadside Snow: 0

Road Surface Condition: 3 - Black Ice
Black Ice

Chain Restriction: 2 - Condition B - Chains Required on vehicles towing o...
Begin MP: End MP:

TripCheck

Commercial Restriction: 0 - <No Restriction>
* Low visibility is defined as less than 500 feet.

Public Comments
Use caution - Wide areas of black ice

Expiration Date: 05-19-2008 22:40 Print/Email Save Save and Close Cancel

Reviewed

Road and Weather History
Road and Weather updated on or after: 04/19/2008 format = (mm/dd/yyyy) Search Copy History to Excel

Station #	Entry Date/Time	Recorder	Reviewer	Cur Temp	Weather Cond	Road
20	2008/04/29 13:55	Juston Glea...	Juston Glea...	23	Snow Flurries	Spots

TripCheck





HTCRS

View/Edit Incident #50876; related to Alert#3355 - HTCRS 2.5.6 Microphone Tools

Location

*Route: ORE46

*Highway: 38 OREGON CAVES; MP: 0 - 19.33

*Begin MP: 13 Construction incidents auto check for 'Construction' incidents

End MP: 14

Marker:

Affected Lanes

Westbound: M A B C D E S All

Eastbound: M A B C D E S All

Off-Highway Options

None

Incident Type and Severity

Key In:

Or Select:

*Category: CV - Commercial Vehicle Information

*Severity: 4 - Closure

Dates/Times

*Start Date/Time: 05/15/2008 09:40

*Estimated Clear Date/Time: 06/15/2008 09:40

Cleared Date/Time:

Public Information Internal Information Incident Information History

Common From: ORE46, 6 miles West of Oregon Caves National Monument

Name To: ORE46, 5 miles West of Oregon Caves National Monument

Headline: **Closed to all trucks**

Chars allowed: 150
Chars used: 20
Chars Avail: 130

Public Comment:

*Contact Name: ODOT/NWTOC Salem Contact Phone: (800) 977-6368

Info URL:

Reviewed: hwy09k
(note: * = required field)



OnStar Incident Data

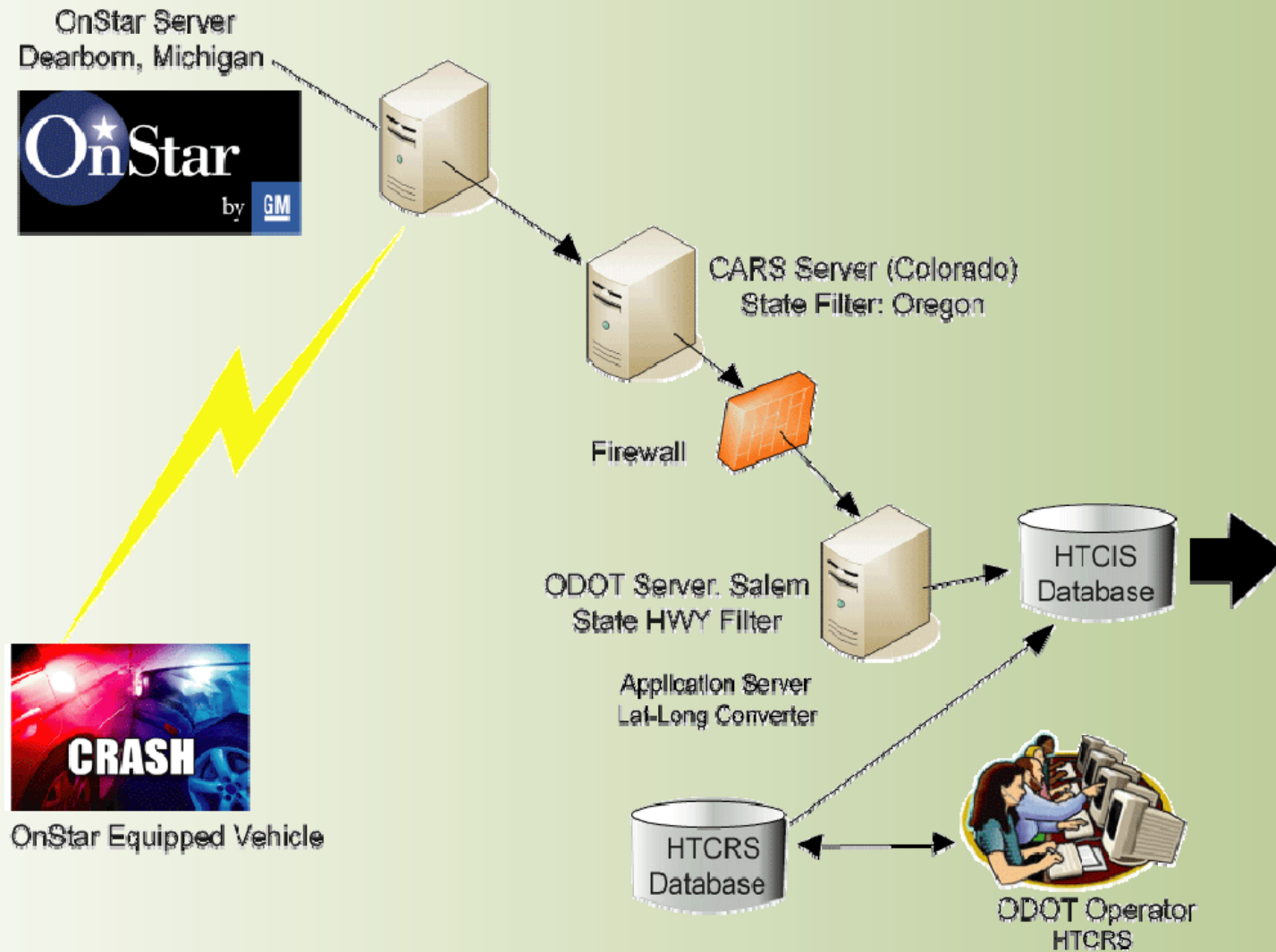



Weather Warning Systems

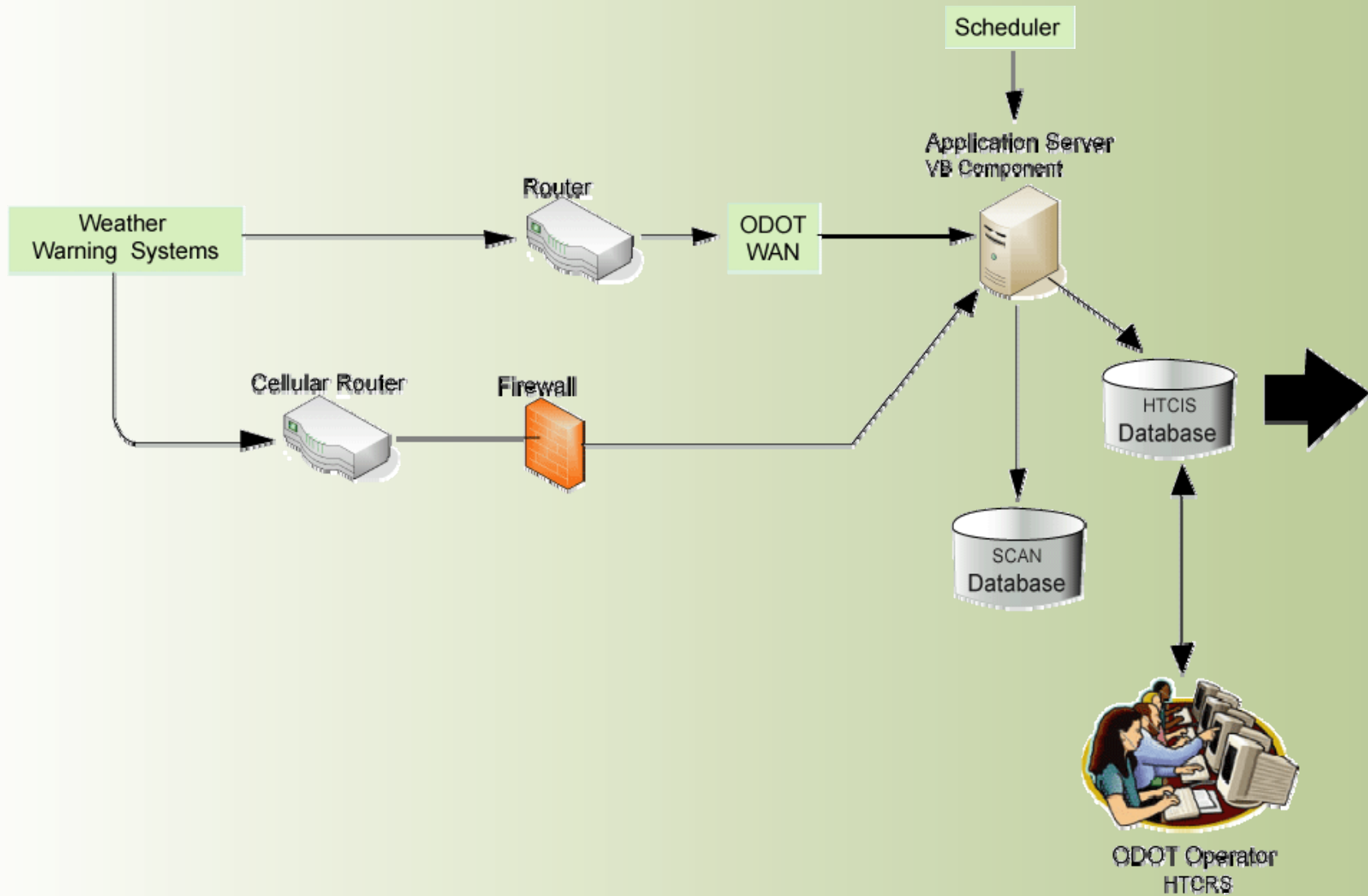



Cable TV

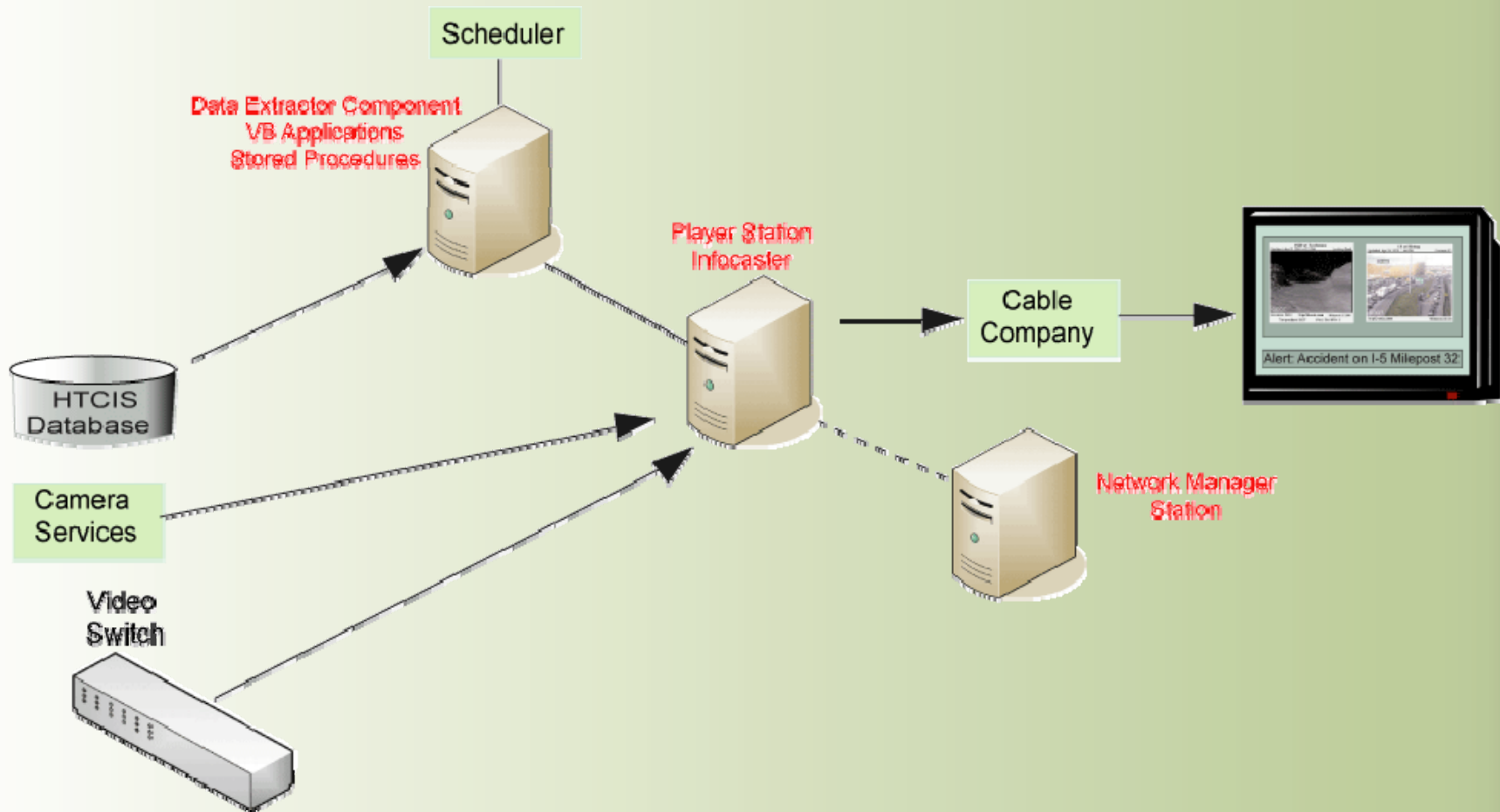



InfoCaster™

Digital Signage Solution

➤ Create, Manage and Deliver Your Message



- Third party software Harris/Inscriber
- Receives processes data and images
- Three components
 - Player
 - Creation / Player
 - Network Manager



Creation

InfoCaster 2.0.8 <Creation Station> - [BurnsDMVCableTV 1024x768]

File Edit Regions Tools Help

New Open Pages Regions Items Play Stop ON AIR

Tree View

- SnakeRiver_pid1405
- 26US
- GovernmentCamp_pid13
- US97
- GreenSpringsInterchang
- ModocPoint_pid1493
- Chemult_pid1493
- LaPine_pid1493
- LavaButte_pid1393
- Redmond_pid1412
- RexBarber
- JuniperButte
- [L2] Lower Left - Still
- Sequence 1
- [L3] Digital Clock
- Sequence 1
- [L4] Alert - Still
- [L5] Alert - Crawl
- [L6] Roadwaydata - Still
- Roadwaydata
- Text-Box-No-Incidents
- Text-Box-TripCheck
- Text-Box-Charter
- Roadwaydata Still - yes
- Blank Item
- [L7] Roadwaydata - Roll
- Roadwaydata Roll - yes
- RoadwayData - yes
- Roadwaydata Roll - no

Regions

BurnsDMV

0 50 100 150 200 250 300 350 400 450 500 550 600 650 700 750 800 850 900 950 1000

Stills

Crawl

Roll

Video

Digital Clock

Analog Clock

Roadwaydata - Still

Background - Still

Lower Left - Still

Lower Still

Alert - Crawl

Details: Roadwaydata - Still

Name: Roadwaydata - Still

Position: 65 From Left 115 From Top 896 Width 220 Height

Type: Still

Lock Size And Position Log This Region GPU Acceleration

Region Permissions

Windows Taskbar: Start, Windows Tas..., InfoCaster..., InfoCaster N..., Catalyst Con..., Incoming, RoadwayDat..., D:\Incoming]..., 12:03 PM





InfoCaster™

Creation

The screenshot displays the InfoCaster software interface. The main window is titled "Roadwaydata - Still [Still]". The interface is divided into several sections:

- Tree View:** A hierarchical list of items on the left side, including "SnakeRiver_pid1405", "26US", "GovernmentCamp_pid1313", "LS97", "GreenSpringsInterchange", "ModoPoint_pid1407", "Chemult_pid1394", "LaPine_pid1392", "LavaButte_pid1393", "Redmond_pid1412", "RexBarberBridge_pid140", "JuniperButte_pid1396", and a group of "Roadwaydata" items.
- Item Library:** A central area with a "Title Quick Editor" and buttons for "Add", "Edit", and "Delete". It contains several item thumbnails: "Blank Item", "Text-Box-Cha", "Text-Box-No-I", and "Text-Box-Trip".
- Sequencer:** A panel on the right for configuring the sequence. It includes "Sequence Settings" with options for "Start Sequence At" (12:00:00 AM), "Default Duration" (0 h 0 m 5 s), "Default Transition" (Dissolve), "Duration" (1.0 s), and "Softness" (0 %). There are checkboxes for "Play From First Item", "Loop Sequence", and "End Item Before Changing Sequences". Below this, a sequence list shows items like "Text-Box-No-Incident", "Text-Box-TripCheck", and "Text-Box-Charter" with their respective schedules and durations.
- Details:** A panel at the bottom right showing metadata for the selected item "Text-Box-No-Incidents", including "Format: icg", "Size: 270 KB", and "Modified: 04/23/2008 10:50".
- Preview:** A small window at the bottom left showing a video preview of the selected item.

The Windows taskbar at the bottom shows the Start button, Windows Taskbar, and several open applications including InfoCaster, Catalyst Con..., and Incoming. The system clock shows 12:08 PM.





Network Manager

InfoCaster Network Manager Standard Version 3.0

File Edit Tools Help

InfoCasts InfoCast Settings Players Players Playback NM Clients NM Servers NM Publishers Status

XD0440CCTV3 - SalemITS

XD0440CCTV4 - LaGrande Player1

XD0440CCTV5 - Corvallis Player 1

XD0440CCTV6 - SalemTLby Player 1
Not Connected

XD0440CCTV7 - PDXFLby ...

XD0440CCTV8 - BurnsDMY Player 1

XD7606CCTV1 - Bend Creation1

XD7606CCTV2 - Bend Player 1

Help Connected [1] Close





Player



Demo



TripCheck Traveler Information Portal

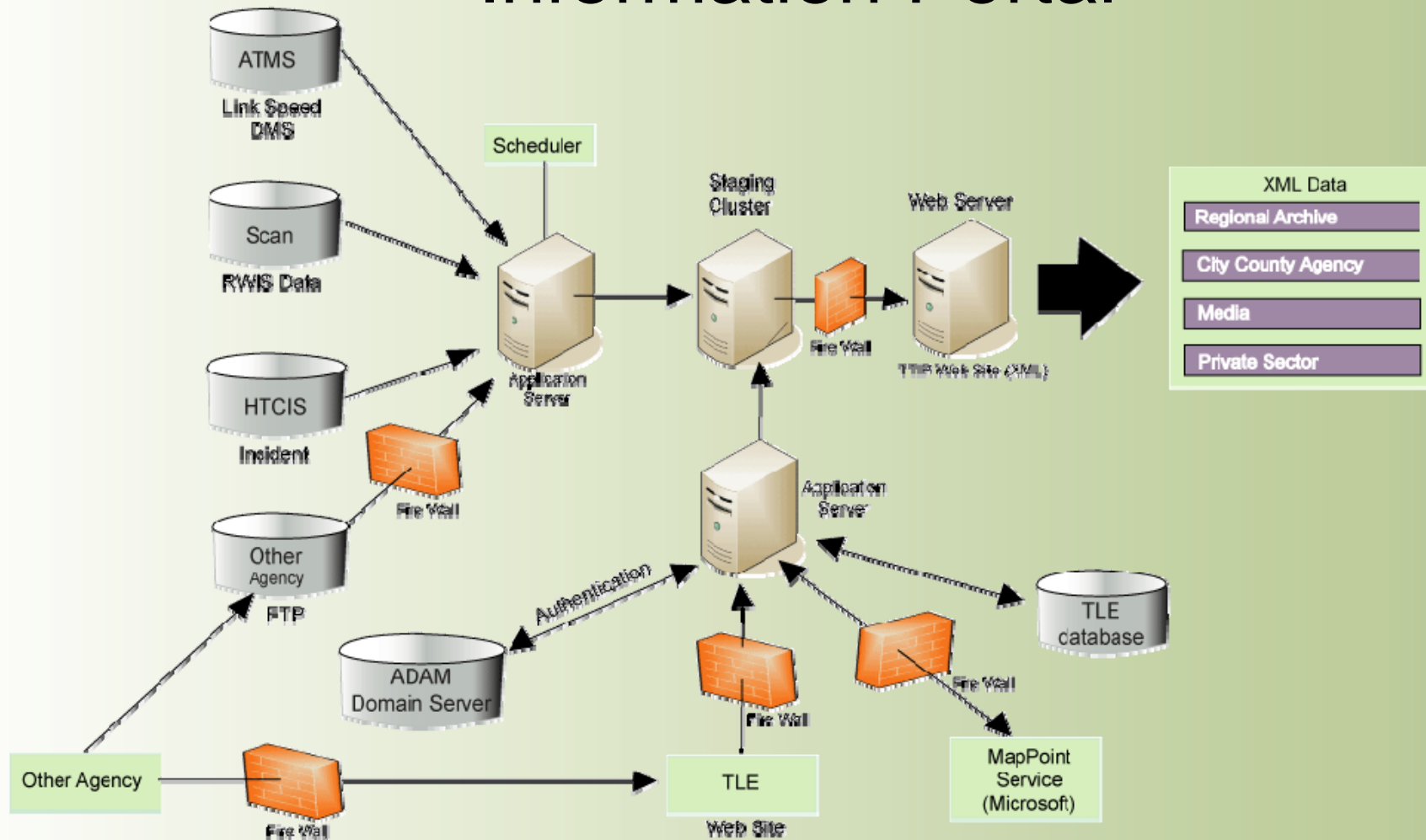



TripCheck Local Entry

TripCheck Local Entry Portal HOME CONTACT LOGOUT

Events / Pending TTIP Approval Users Account Your Login Lists & Reports

EVENTS ! You have new events pending TTIP publication approval. [Click here](#) to view.

TIPS
Click on the "hand" icon and then click on an event icon to view event details, edit the event, or create an event WORD doc.

Show: **All Events**

of impact: **All Impacts**

of type(s):

- Emergency Response
- Crash
- Inclement Weather
- Flooding
- Obstruction
- Construction
- Maintenance
- Bridge Opening
- Planned Event

VIEW / EDIT EVENTS **ADD EVENT** **TABLE VIEW**

Zoom to Jurisdiction: **Select from list** GO





TripCheck & Mobile Web Sites

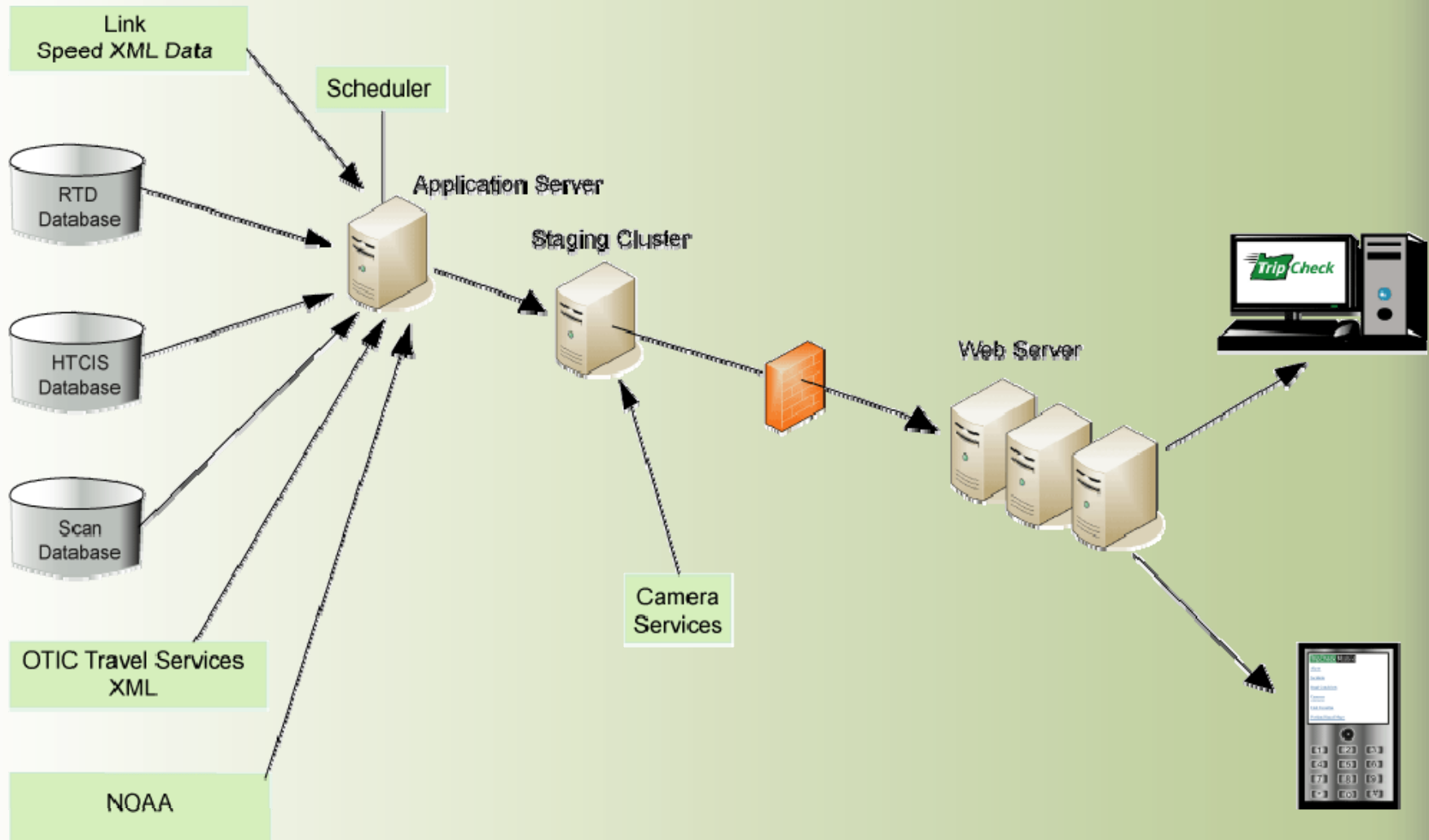



TripCheck Mobile

TripCheck Mobile

[Alerts](#)

[Incidents](#)

[Road Conditions](#)

[Cameras](#)

[Cam Favorites](#)

[Portland Speed Map](#)

[Travel Services](#)

[Construction](#)

[Trucking Restrictions](#)

Portland Speed Map



I-5 at Rosa Parks Way



[View Smaller Image](#)



511 Mobile Voice

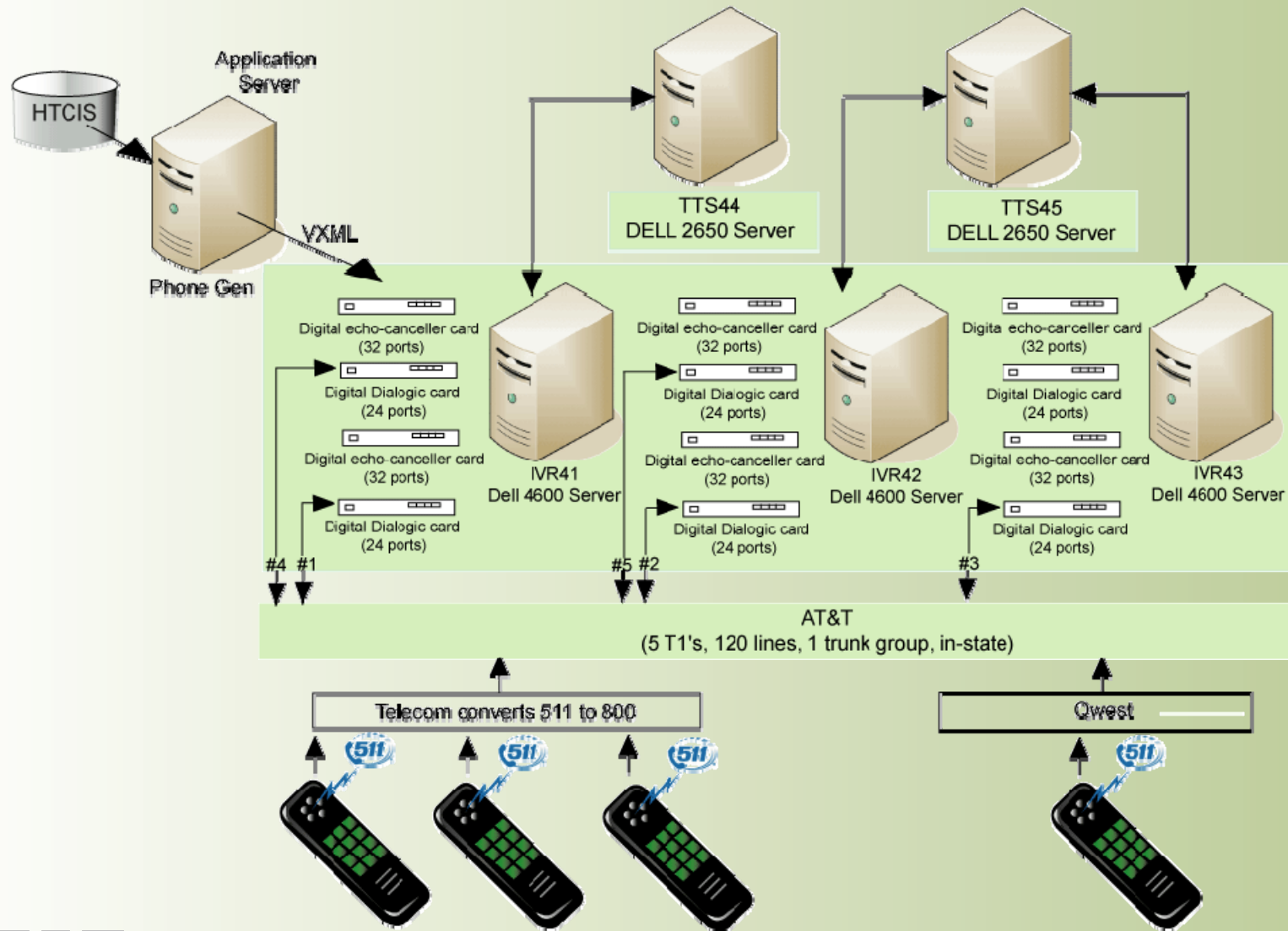



About the Web Infrastructure

- Staging Cluster
 - Clustered for redundancy
 - Manages & simplifies replication of data to web servers
- Web Server Cluster
 - 3 servers in cluster
 - Load balancing
 - Redundancy



Systems Monitoring

- Argent
 - Cost
 - \$800/year Server license
 - \$200/year/server monitored
 - Monitor
 - Services
 - File updates
 - Log files
 - Notification
 - Pager & Email on failure and on recovery
- Camera Services
 - Monitor image file updates
 - Replace image after 2 hours
 - Notification
 - Email notification after 1 hour



Systems Monitoring

- Web Pulse
 - External web site monitoring
 - Run script against web site
 - Frequency
 - TTIP System – 15 minutes
 - TripCheck – 30 minutes
 - Forced monitoring on failure – 1 min. until recovery
 - Cost
 - \$90/month
 - Email notification on failure and recovery



Systems Monitoring

- AT&T Business Direct
 - Monitoring of phone line status
 - Cost
 - \$200/month
 - Email notification on failure
- Custom Software Components
 - Monitor
 - Write file
 - Receive file
 - Notification
 - Email on failure



Staffing and Support

- System Admin/Support (\$370,000/biennium)
 - TripCheck Support – 1.5 FTE
 - ITS Operations Coordinator
- System Maintenance (\$300,000/biennium)
 - ITS Staff
 - 2 fulltime (lead, programmer) and 1 contracted
 - Data Base Analyst
 - Tech Management
 - Server support
 - Network support
 - Web Infrastructure
 - 2 ODOT, multiple at State Data Center



Lessons Learned

- Build business process first
- Public expectations are high
- Plan for 24 x 7 support
 - Build redundancy where possible
- Automated system monitoring is essential
 - Build systems with monitoring in mind
- Performance measures help improve data quality